

SLIDING & FOLDING SYSTEMS

FOR DOORS & WARDROBES

IN WOOD & GLASS

Manufacturing Relationships
Distributing Quality



WOODEN FRAME DOORS

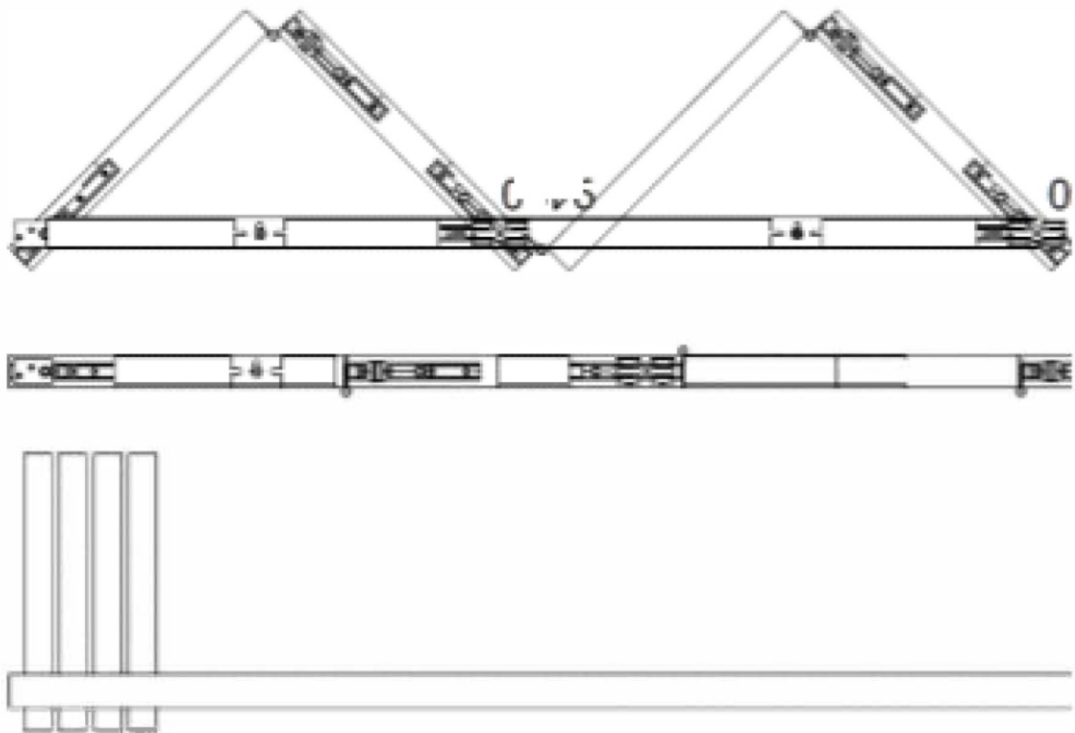

PLATE TYPE FOLDING DOOR CENTER FOLD

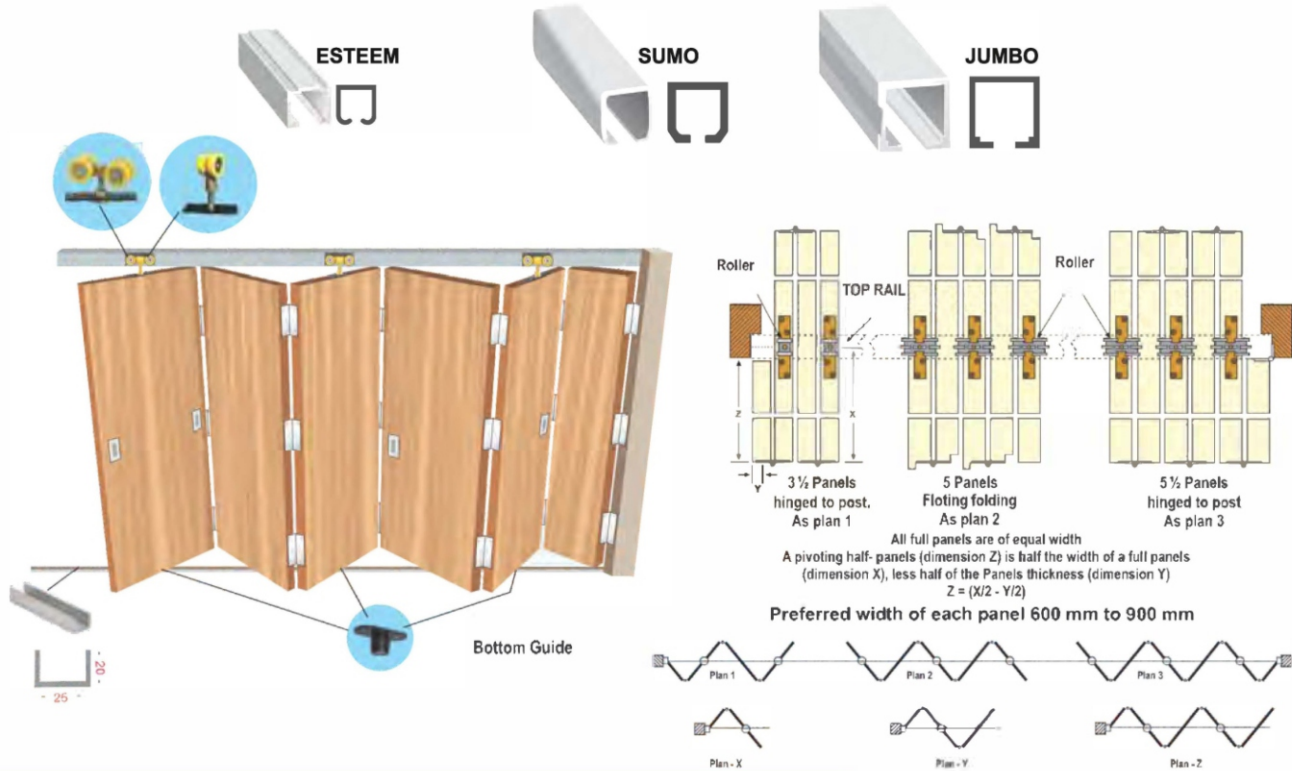
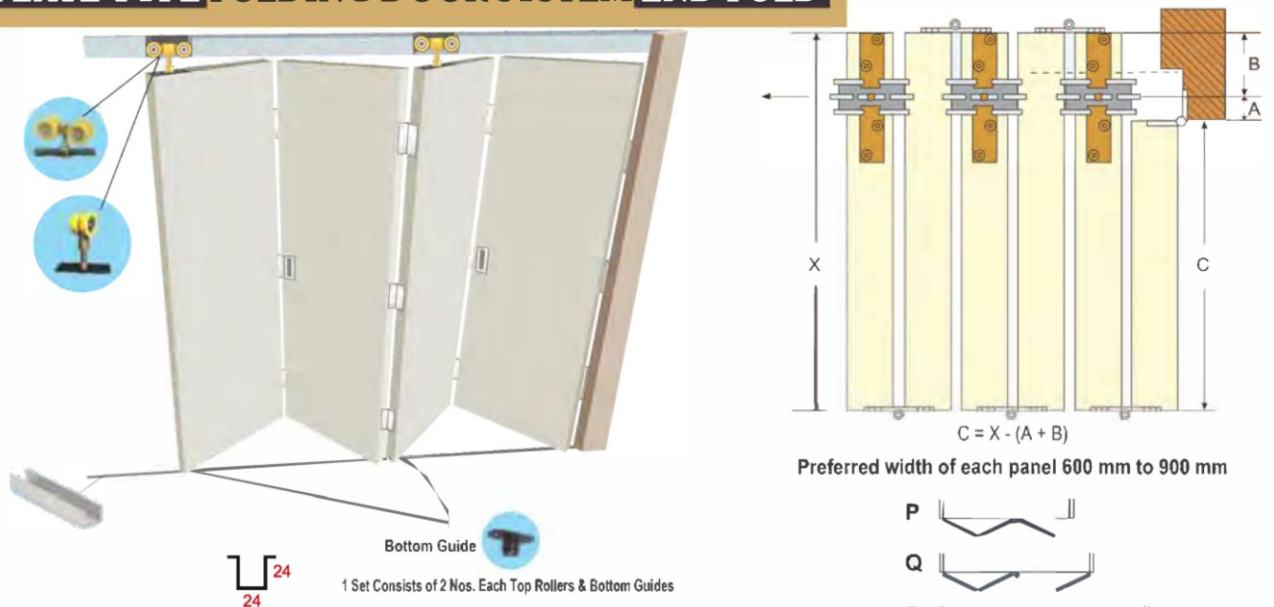

PLATE TYPE FOLDING DOOR SYSTEM END FOLD



CATLOG SR No.	DOOR WT.	ROLLER TYPE	TOP RAIL	BOTTOM RAIL
1	20 kg.	MINI SUMO	MINI SUMO	BOTTOM RAIL
2	40 kg.	MINI SUMO		
3	40 kg.	SUMO 0.20	SUMO	
4	60 kg.	SUMO 0.40		
5	100 kg.	JUMBO 0.20	SDMBO	
6	150 kg.	JUMBO 0.40		

SLIDING FOLDING SYSTEMS PREMIUM SERIES
PLATE TYPE SOS02 - END OR CENTRE FOLDING



Main Material: Premium Bearing, Alloy, Steel, Nylon

Finish: Nickel, Satin Nickel Weight Capacity : 60 Kgs / Door

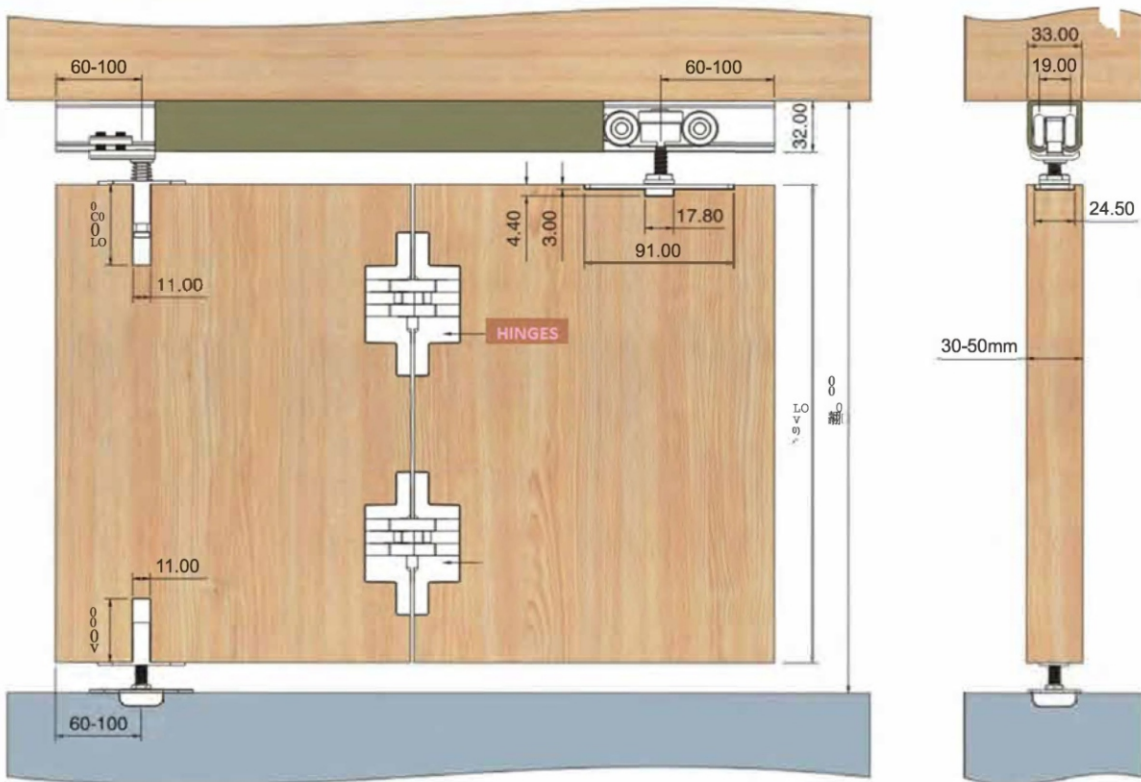

SLIDING FOLDING SYSTEMS HENDERSON TYPE
PLATE TYPE HEAVY DOORS END OR CENTRE FOLDING

Fitting Instructions End Fold

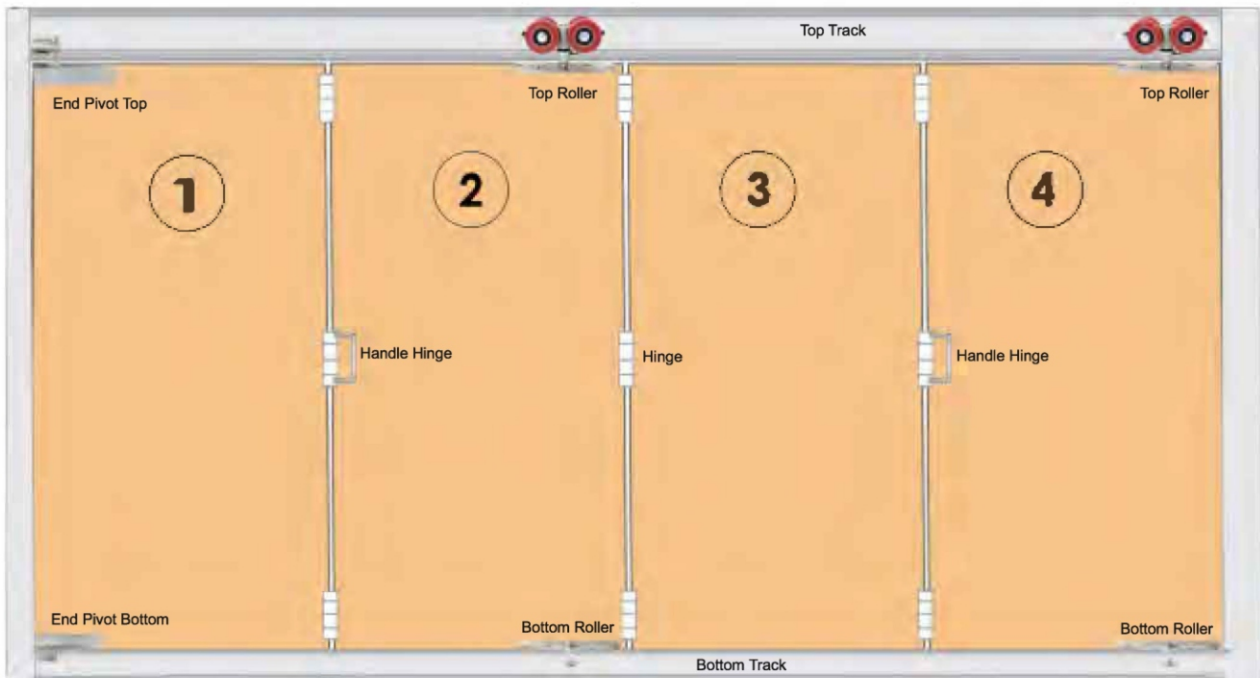

Fitting Instructions Center Fold

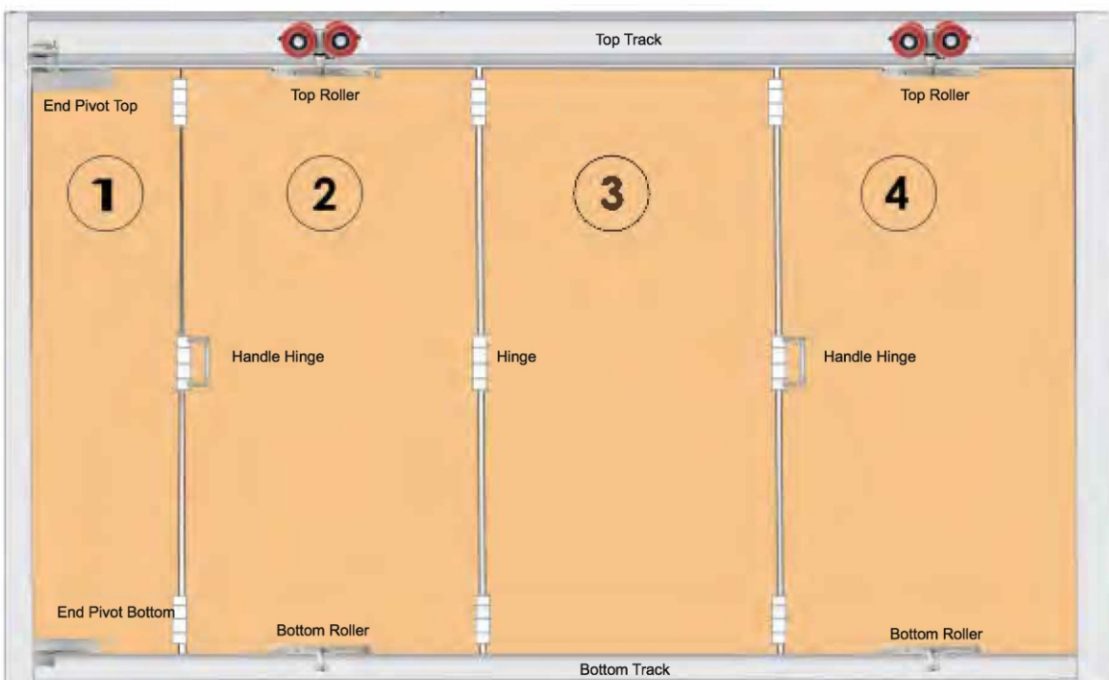

Weight Capacity : 100kg / Panel

Max. Door Height : 2700mm & Width : 950mm

HINGES TYPE SLIDING FOLDING SYSTEMS

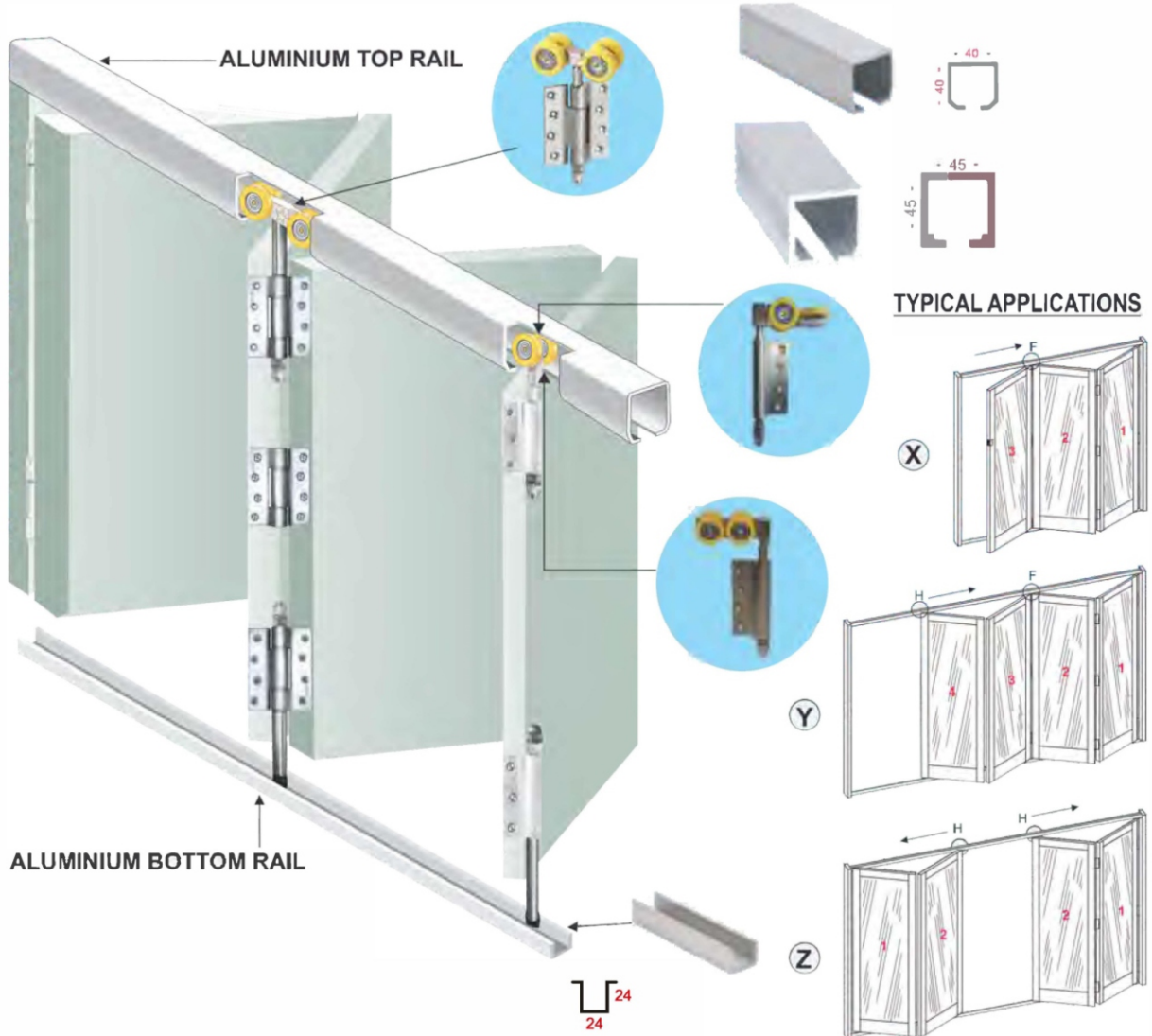

FULL SET			
DOOR WT.	ROLLER TYPE	TOP RAIL	BOTTOM RAIL
40 kg.	SUMO	SUMO	} BOTTOM U
100 kg.	JUMBO	JUMBO	
150 kg.	JUMBO	JUMBO	

HALF SET			
DOOR WT.	ROLLER TYPE	TOP RAIL	BOTTOM RAIL
40 kg.	SUMO	SUMO	} BOTTOM U
100 kg.	JUMBO	JUMBO	
150 kg.	JUMBO	JUMBO	

SLIDING FOLDING SYSTEMS HENDERSON TYPE
HINGE TYPE TECHNICAL DRAWING

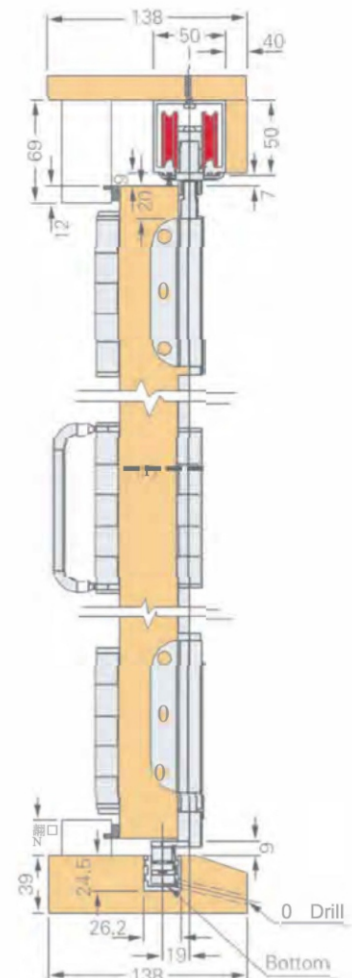
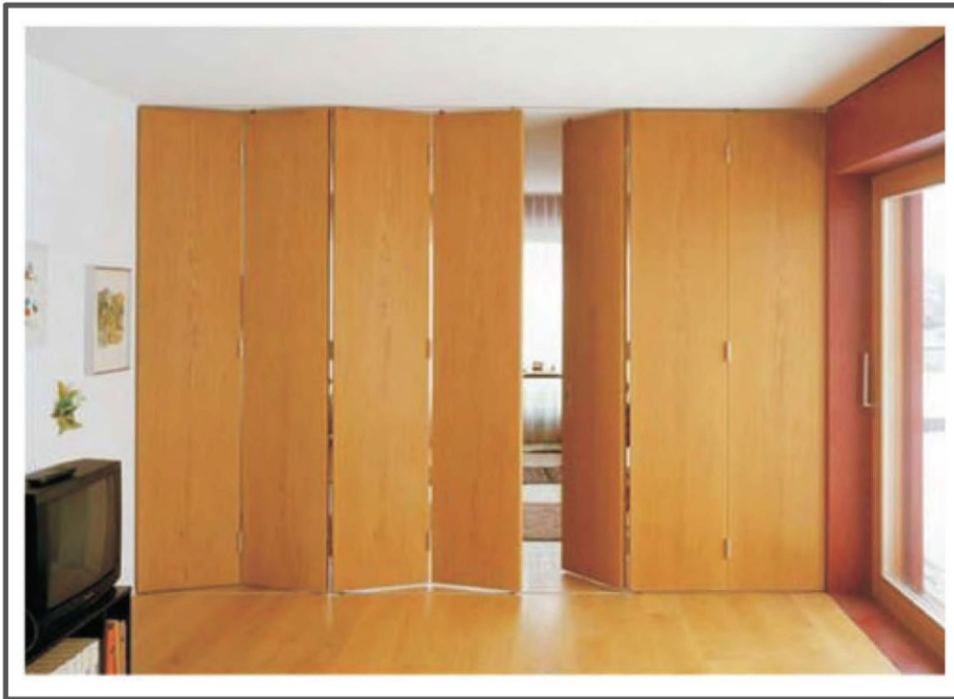

TECHNICAL DATA

- Max Door Height : 3300mm
- Max Door Weight : 100 kg
- Max Door Width : 900 mm
- Max Door Leaves : 8
- For Door Thickness : 35-50 mm
- Min. Track Radius : 5000 mm
- Upper Running Track : Aluminum, anodized
- Upper Hanging : Nylon gear and SUS304 suspended fitting
- Hinge : SUS304
- Hanging Rollers Body : SUS304

Bottom Guides

High precession bearings and SUS304 suspended fitting
Bottom running track: Aluminum, anodized Support gasket for bottom track : Invisible PVC

SLIDING FOLDING SYSTEMS HENDERSON TYPE
HINGE TYPE TECHNICAL DRAWING

BOTTOM TRACK VIEW

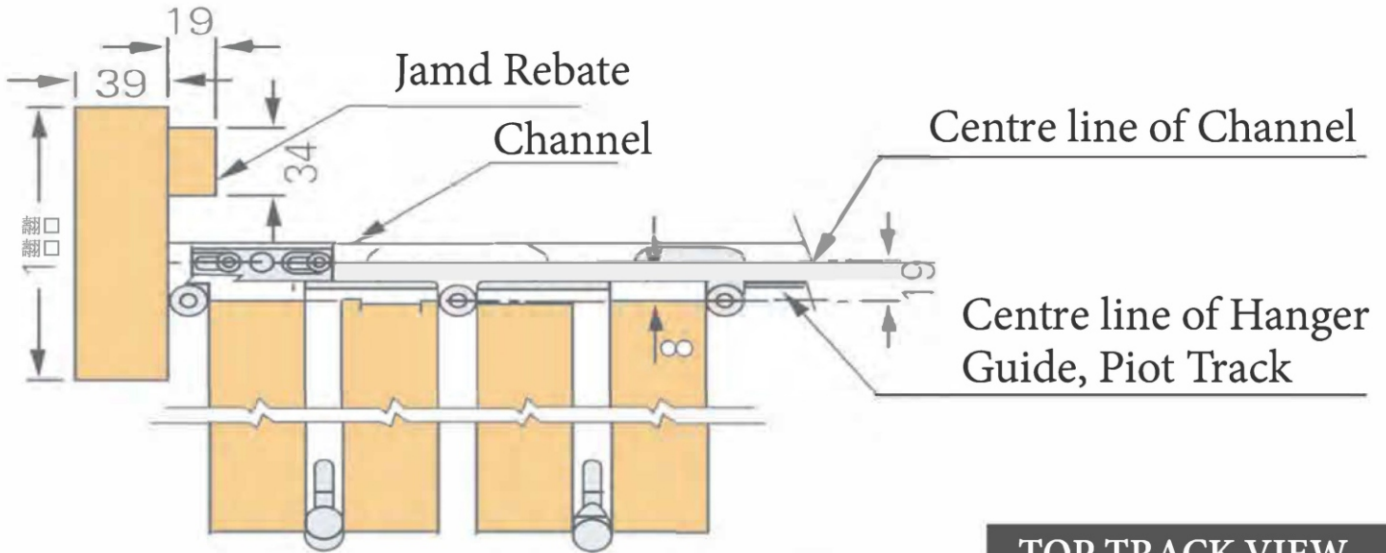

TOP TRACK VIEW

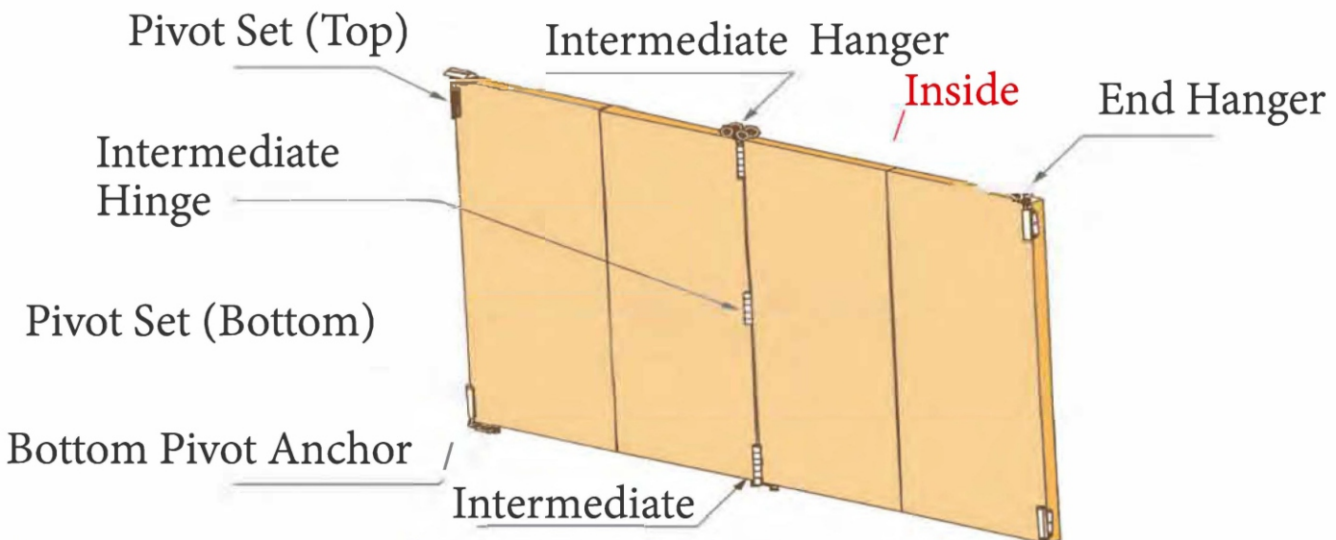
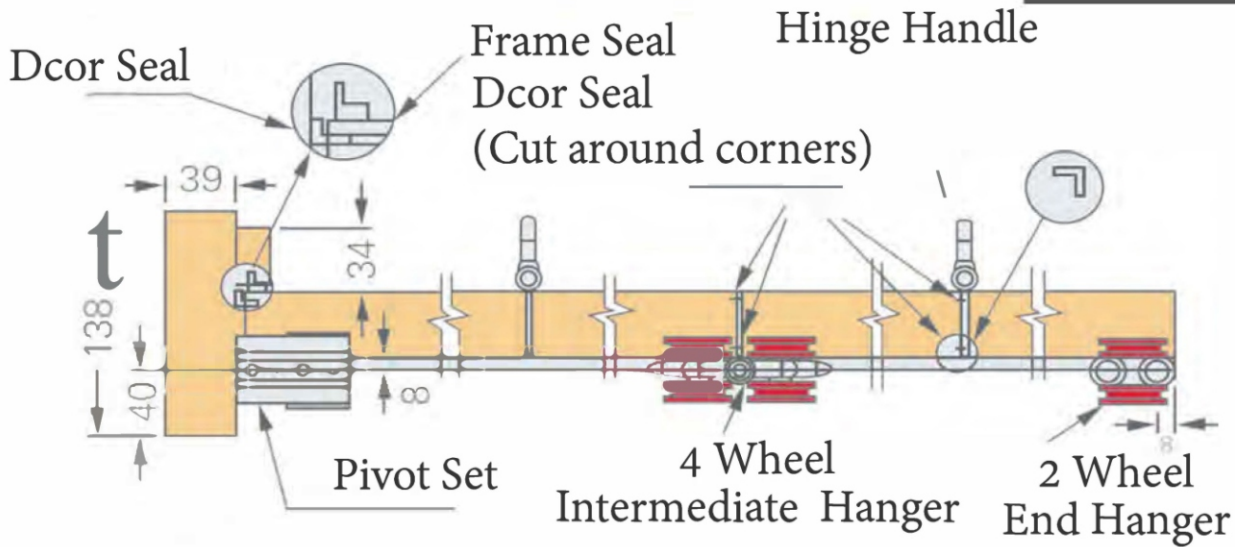

GLASS SLIDING FOLDING



GLASS SLIDING & FOLDING HENDERSON TYPE END FOLDING

511 P / S.S. 304

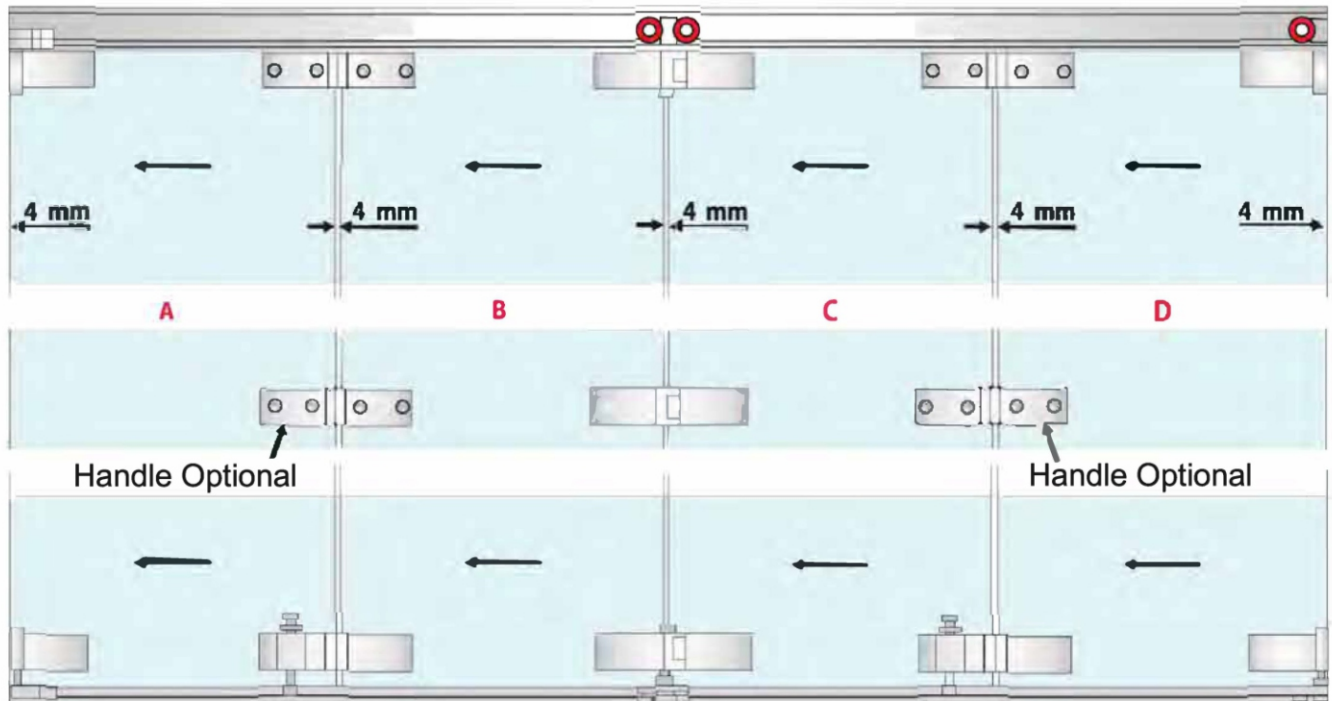

Glass Preparation for A, B & C

Glass Preparation for D

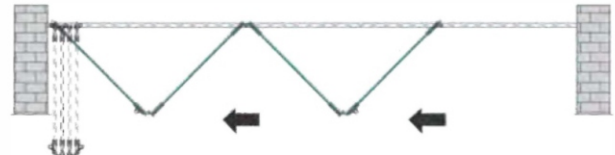
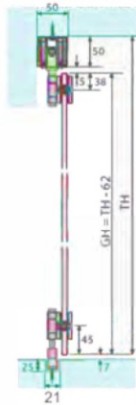
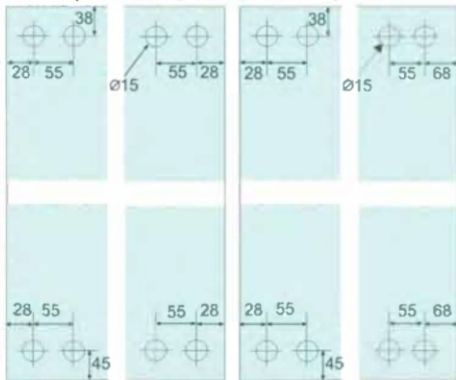

Product	Name	Name	Name	Name	Name	Name	Name
For 2 Glass Panel	01 Set	01 Set	--	01 Set	As Per Optional	01 Set	01 Set
For 3 Glass Panel	01 Set	01 Set	01 Set	--	As Per Optional	01 Set	01 Set
For 4 Glass Panel	01 Set	02 Set	01 Set	01 Set	As Per Optional	01 Set	02 Set
For 5 Glass Panel	01 Set	02 Set	02 Set	--	As Per Optional	01 Set	02 Set
For 6 Glass Panel	01 Set	03 Set	02 Set	01 Set	As Per Optional	01 Set	03 Set

**GLASS SLIDING & FOLDING HENDERSON TYPE
CENTER FOLDING**



PLAN VIEW

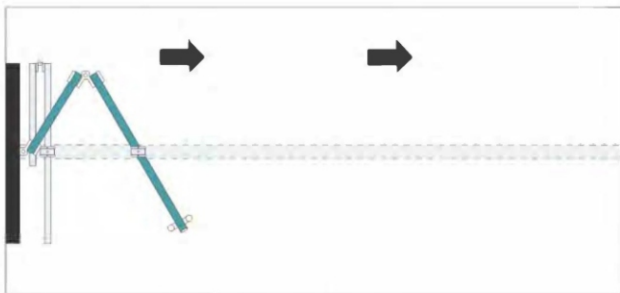

2 Door Panel

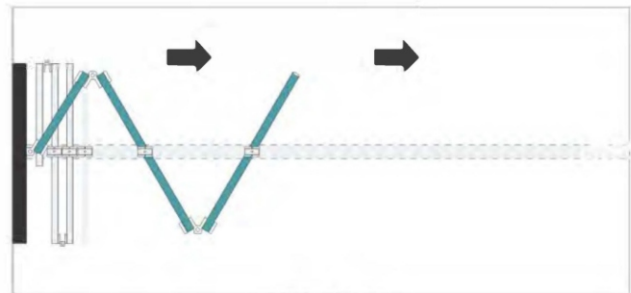

3 Door Panel

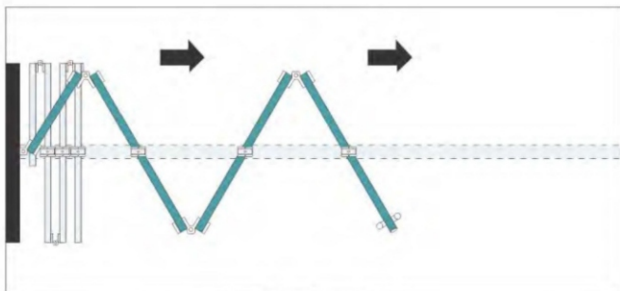

4 Door Panel

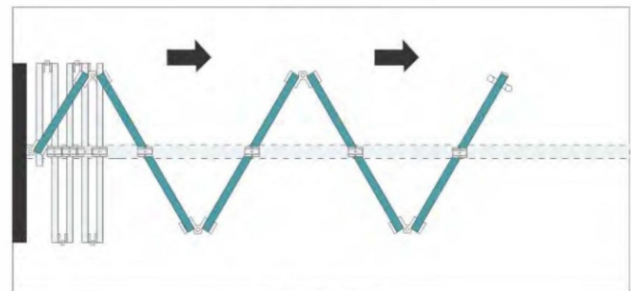

5 Door Panel

GLASS SLIDING & FOLDING HENDERSON TYPE CENTER FOLDING

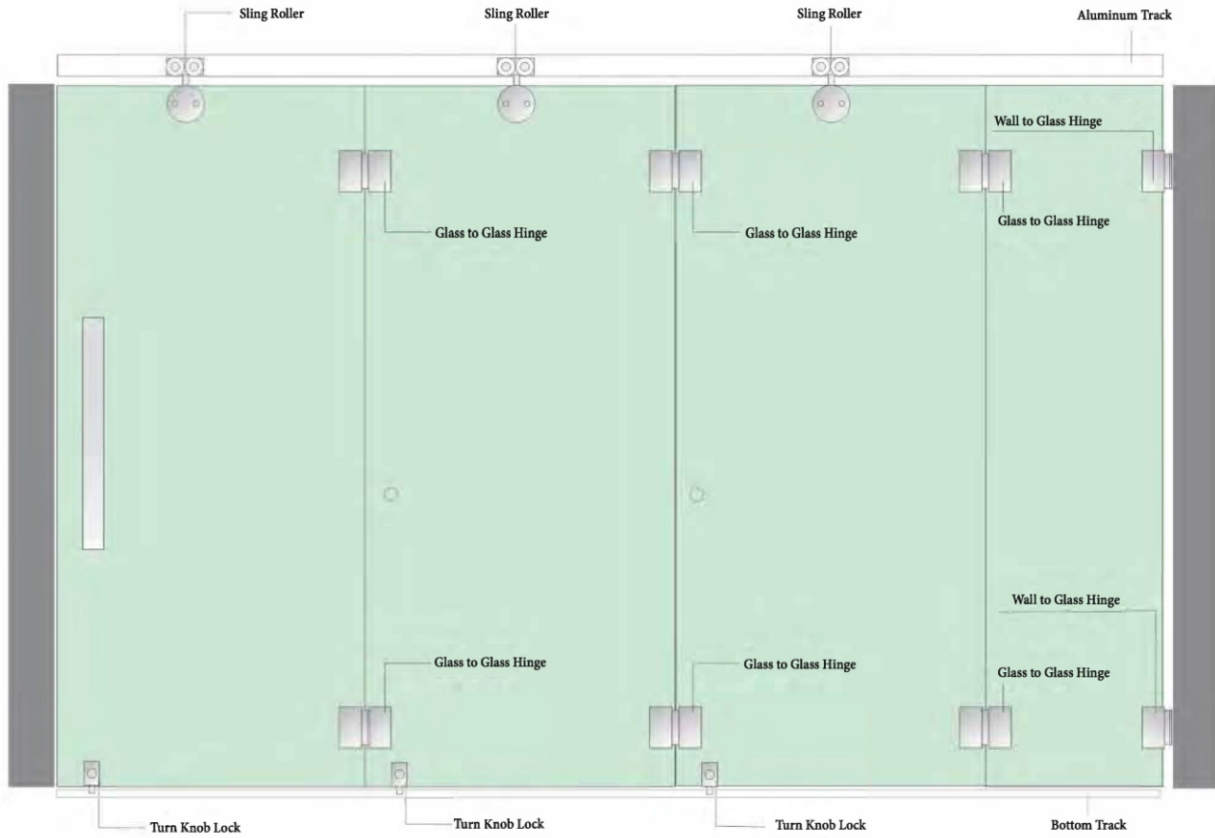

DOOR PANEL	SLIDING ROLLER	WALL TO GLASS HINGE	GLASS TO GLASS HINGE
For 2 Door Panel	1 Pcs.	2 Pcs.	2 Pcs.
For 3 Door Panel	2 Pcs.	2 Pcs.	4 Pcs.
For 4 Door Panel	3 Pcs.	2 Pcs.	6 Pcs.
For 5 Door Panel	4 Pcs.	2 Pcs.	8 Pcs.

MOVABLE GLASS PARTITION PARKING SYSTEM



PLAN VIEW

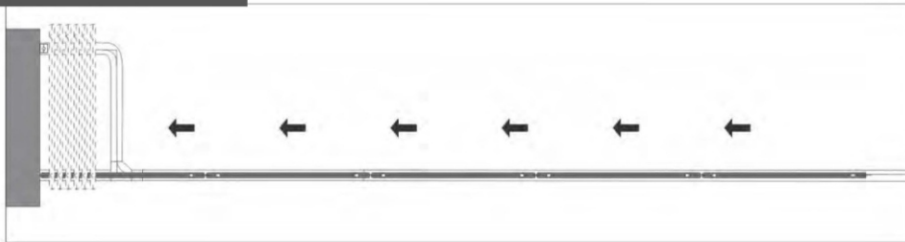

Lower Door (Single Latch)



Upper Door Strip/Shaft Sleeve



Upper Door Strip/Roller



Lower Door Strip (Duble Pins)



Lower Door Strip



Lower Door Strip L/R



Lower Door Strip L/R



Lower Door Strip
(Surface Bolt + Side Bolt)



Track



Rail (T Piece) L



Rail (T Piece) R



Rail (Elbow)

MOVABLE GLASS PARTITION PARKING SYSTEM

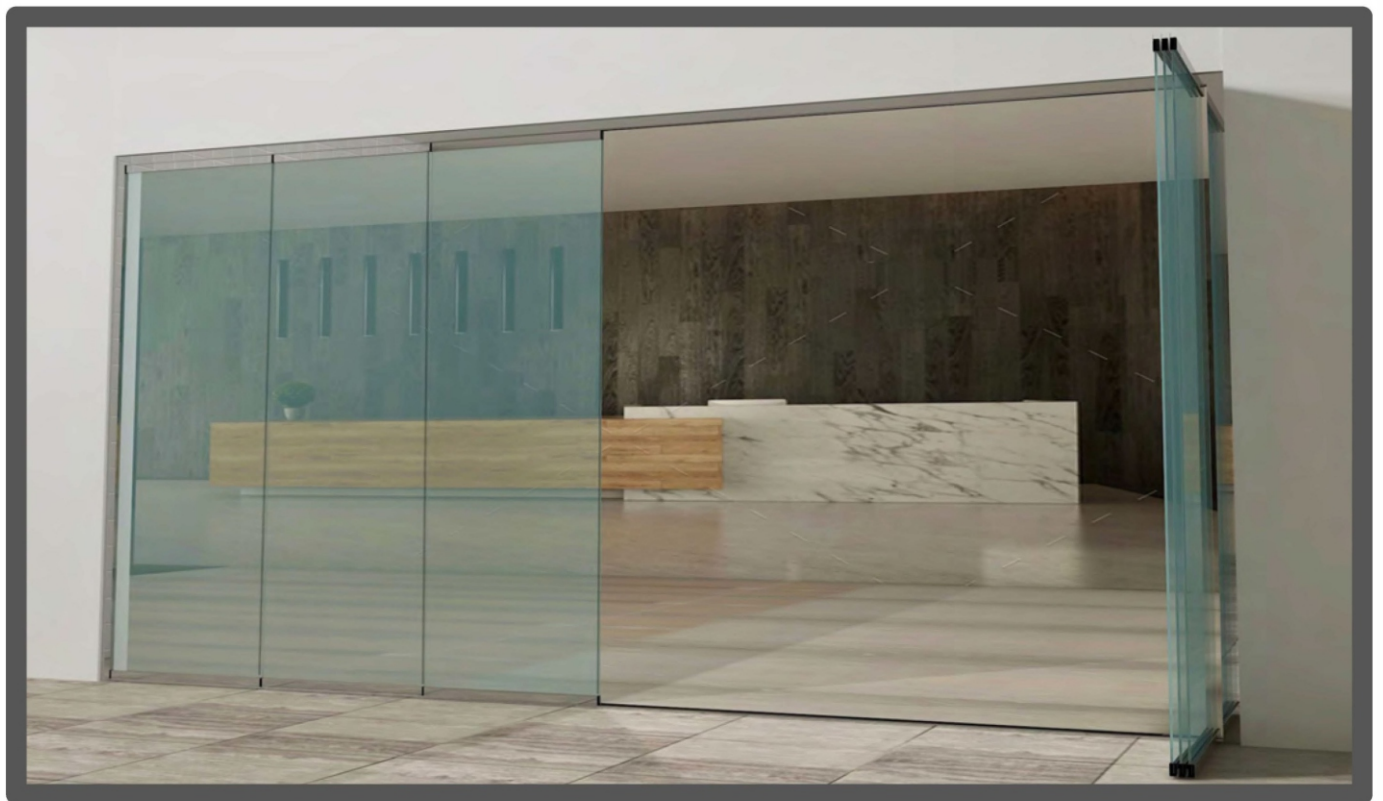

WARDROBE SLIDING FOLDING



WARDROBE SLIDING & FOLDING WING FOLD SYSTEM



ZSFD-08

CAPACITY : 15 KG
DOOR WIDTH : 300-350MM
DOOR HEIGHT : 2400MM (MAX)
DOOR THICKNESS : 19 MM
2 WING FOLD ACCESSORIES

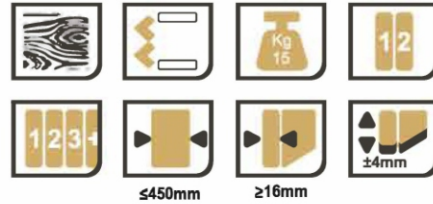

WARDROBE SLIDING & FOLDING WING FOLD SYSTEM

Cabinet Requirements

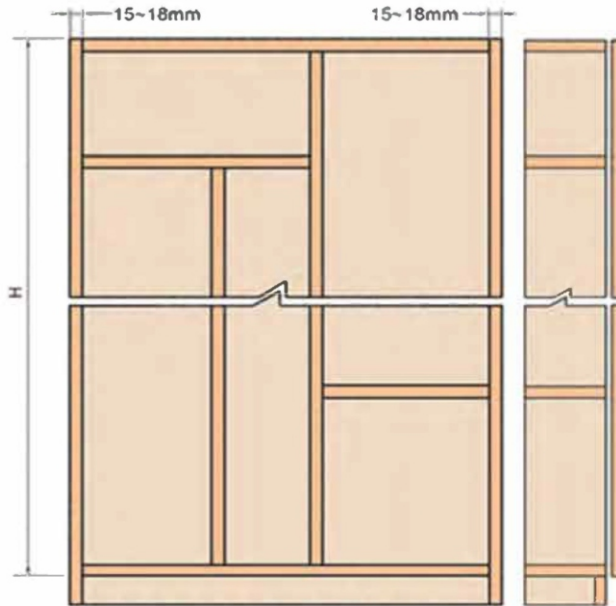

Hole Drilling Dimensions

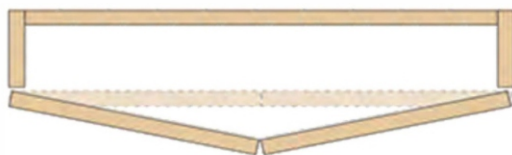
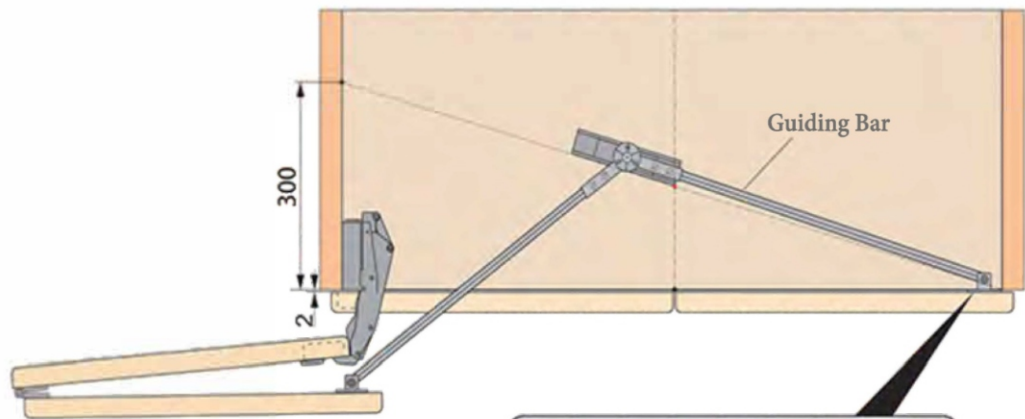
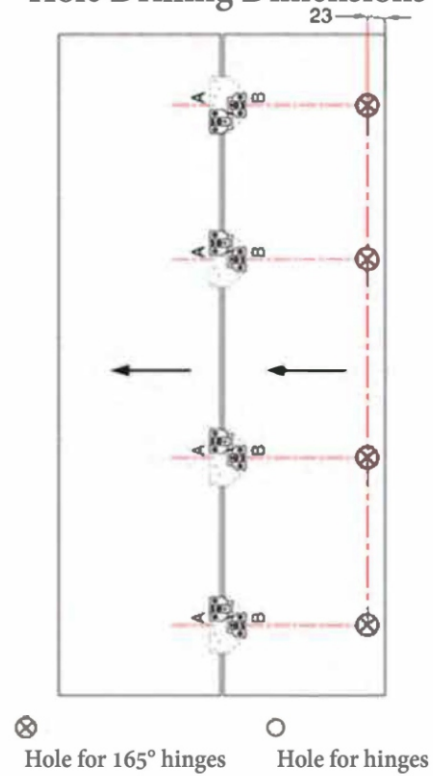

Soft Closing

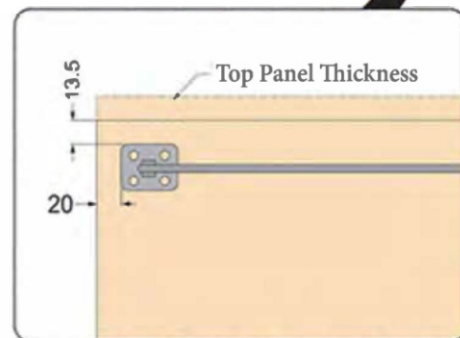

**WARDROBE SLIDING & FOLDING
2 & 4 DOOR SYSTEM ECO SERIES**

Product Name DSFD 04

**Top + Centre + Bottom, Weight Capacity
- 20kg, 2 Door Roller Set Price - 0000, 4
Door Roller Set Price - 0000**

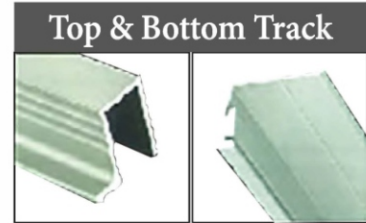

**Top & Bottom Track
Price - 0000**

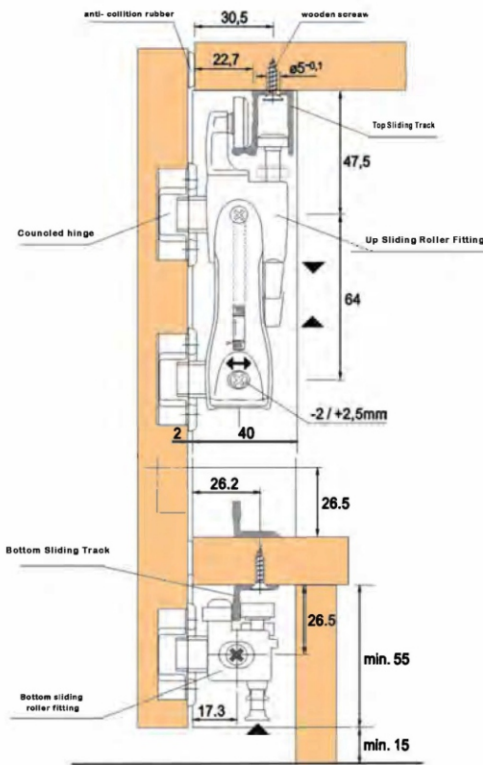

Folding Door Installation Sizes & Flight View

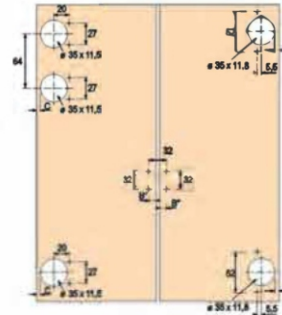

1. Hinge Hole Sizes And Situations

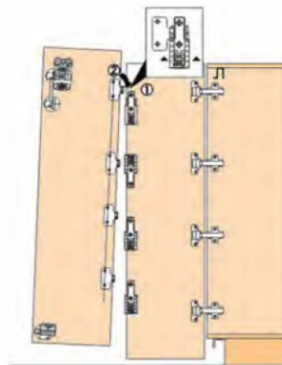

2. Hinge Connecting

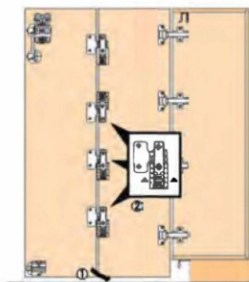

3. Hinge & Flush Bolt Installation

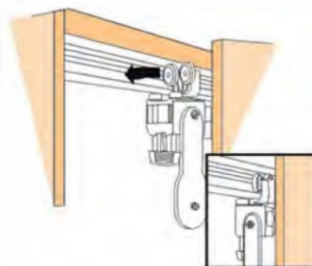

4. Put The Up Roller Into Up Sliding Track

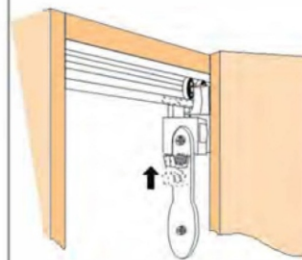

5. Push Up Roller Guide, Make Up Roller Into Up Sliding Track

WARDROBE SLIDING & FOLDING 2 & 4 DOOR SYSTEM PREMIUM SERIES

DSFD -09



ACCESSORIES OPTION

<p>Top Hanging Fittings for Folding Door with Interlinked Hinge</p> <p>Only for 4 panels folding system</p>			<p>Bottom Hanging Fittings for Folding Door with Interlinked Hinge</p> <p>Only for 4 panels folding system</p>	
<p>Top Hanging Fittings for One-wing Folding Door</p>			<p>Bottom Hanging Fittings for One-wing Folding Door</p>	
<p>Hinge</p>	<p>Drilling mode</p>	<p>Up Track</p> <p>0.53kg/m</p>	<p>Bottom Track</p> <p>0.29kg/m</p>	
<p>Folding Door (2 panels)</p>	<p>Multi-wing folding door (4 panels)</p>	<p>Accessories minutes combined installation</p> <p>A. Four door(2+2) B. Six door(4+2) C. Eight door(4+4)</p>		

**WARDROBE SLIDING & FOLDING
2 & 4 DOOR SYSTEM PREMIUM SERIES**

INSTALLATION PARAMETER INTRODUCED

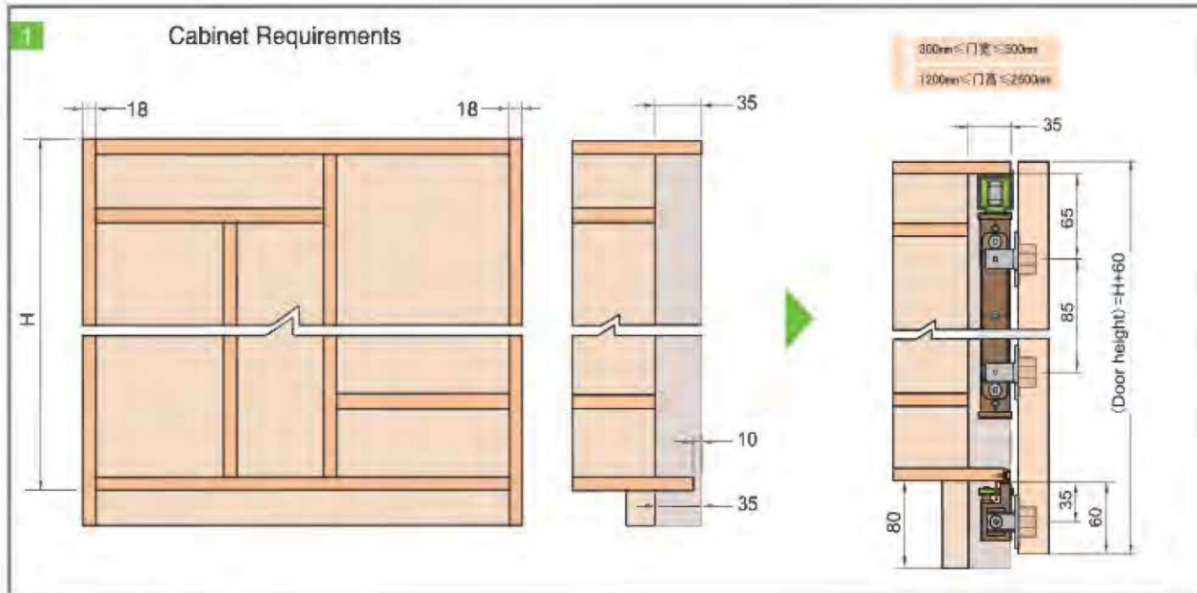

2 Door Requirements

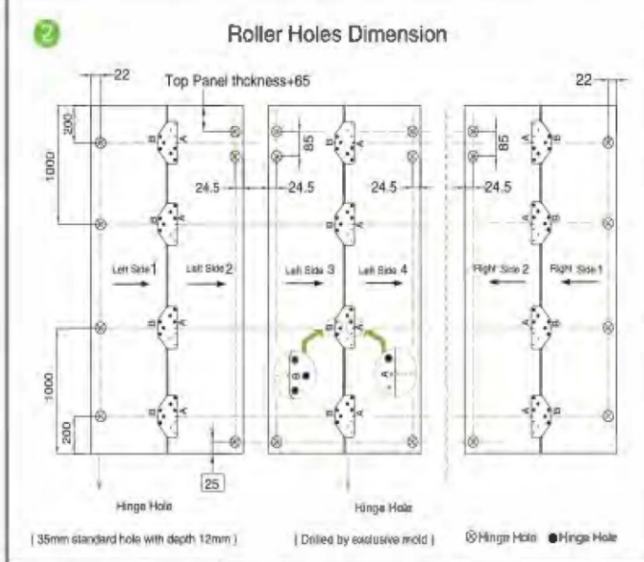
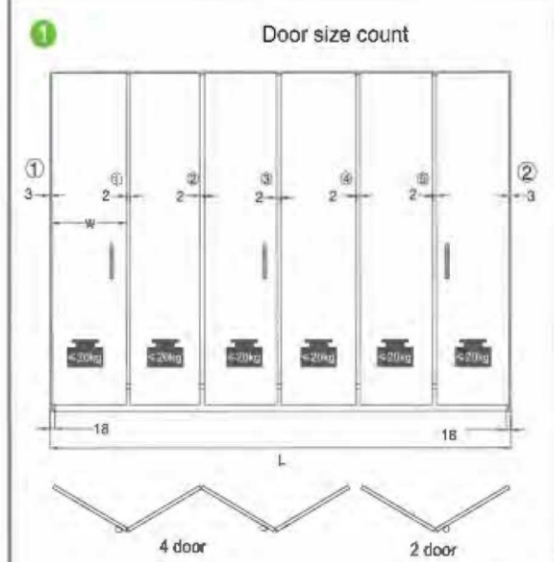

Standard thickness of cabinet side panel is 18mm;
Take 4-wing folding door and 2-wing folding door for example

(Door height) $H=h+60$
1 Door Panel Width $W= \{L-(3+3)-(2X5)\}/6$

"3" means length not covered by door panel on side panel
Normally full-cover hinge is able to cover 15mm only
"5" means quantity of door gap
"6" means quantity of door panel

3 Other Installation Requirements

- 90 degree full cover soft closing hinge
Side hinge of Panel be purchased by customer, factory won't supply it.
- 18mm Door do not have to file
- 45° degree not allowed
90° degree allowed



MSME
MICRO, SMALL & MEDIUM ENTERPRISES
सूक्ष्म, लघु एवं मध्यम उद्यम

UDYAM-MH-19-0138181



BRAND OF

IMPERIAL
HARDWARE

SHOP No. 4, GROUND FLOOR, GOKULDHAM CHS,
32, KIKA STREET, GULAWADI, MUMBAI 400004.

EMAIL: WEASSIST@DIOSINDIA.IN

WEBSITE: WWW.DIOSINDIA.IN

CONNECT WITH US



@ DIOS.INDIA